



NVF3 Series Inverter

1. Overview

As a high-performance open-loop vector controlled inverter developed by our company independently, NVF3 series inverter achieves the high-precision flux vector torque control by using the advanced control algorithm and is characterized by high control accuracy, wide speed range, large starting torque, high reliability, strong overload capacity and flexible operation. The rich and practical speed control, torque control, process closed-loop control, simple PLC, wobble frequency control and multi-speed control can meet a variety of complex high-precision transmission needs.

NVF3 series inverter have two types that are the typical type (heavy load) and fan-pump type (light load), with the functions of strong load adaptability, reliable operation and automatic energy saving operation. It can be widely used in electrical transmission and automation control areas, including lifting, machine tool, textiles, energy, mining, metallurgy, chemical, printing and dyeing, injection molding, foods, cement, water supply, municipal services and papermaking.

The product is designed and tested in accordance with international standards and strictly simulates users' application environment for tests.

The product conforms to standards GB/T 12668.2-2002 and IEC 61800-2.

Typical applications

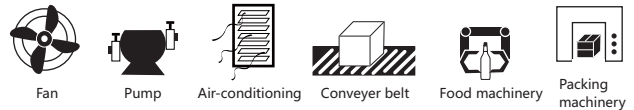

2. Product Characteristics

2.1 Model and meanings

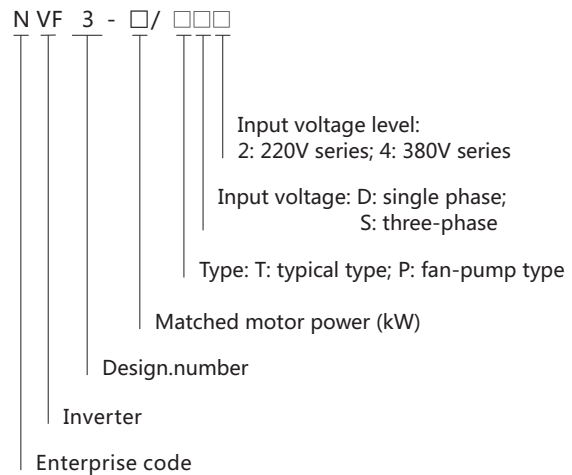

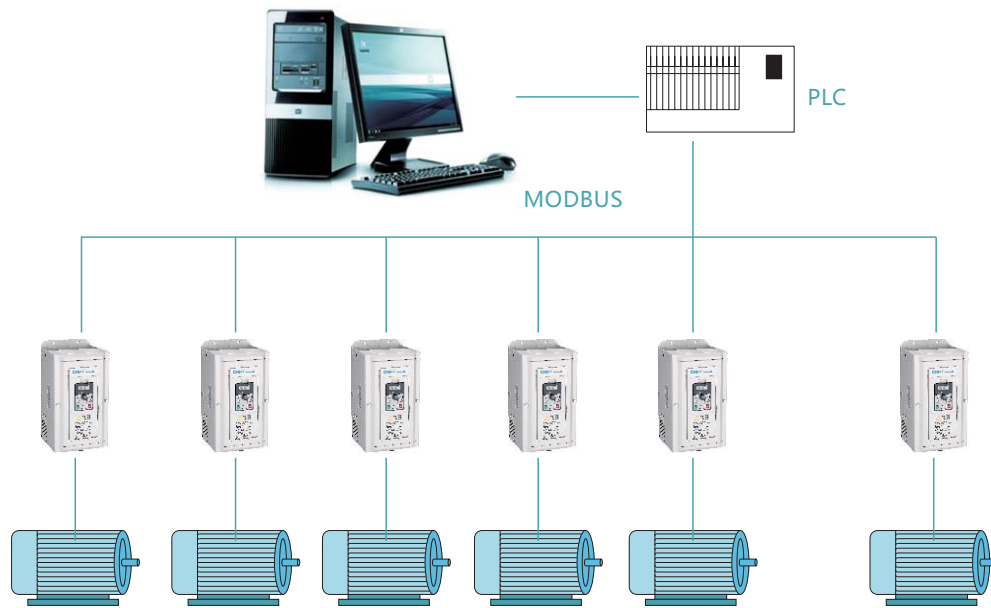

2.2 Excellent motor drive and control performance

- Accurate motor auto-tuning function: accurate auto-tuning of comprehensive and static motor parameters, easy debugging, simple operation, and can improve the control accuracy and response speed;
- Good energy-saving effect: The lighter the motor load is, the lower the efficiency is. Energy-saving control will improve the operating efficiency of motor, so that the motor is always running in the most efficient state no matter how the load changes;
- Unique dead zone compensation technology can improve the output torque;
- High starting torque, 0.5Hz 150% rated torque (without PG control); 0.5Hz 180% rated torque (with PG control);
- Strong overload capacity: lasting for 60s at the rated current of 150% and infrequent overload protection in case of heavy load or load mutation, which ensure the continuous and stable operation of the equipment;
- Wide carrier frequency design: (0.5 ~ 15) kHz, which can effectively reduce the running noise of motor;
- External standard DC reactor (above 110kW) can effectively inhibit the high harmonics and improve the power factor;
- Real-time monitoring: real-time monitoring of DC busbar voltage, motor current and running status to timely know the running status of the system.

2.3 Highly reliable design

- Wide input voltage range: input voltage fluctuation up to $\pm 15\%$;
- The low inductance design enables the system to be more stable and reliable;
- The high-power two-stage DC-DC drive design makes the operation safer and more reliable;
- The input filter design effectively provides lightning protection and reduces harmonic interference;
- The automatic voltage stabilization and automatic current limiting functions make the operation more stable;
- The perfect protection function and fault diagnosis system provide guarantee for the equipment.

2.4 Rich application functions

- Function modular design: the function modular design is integrated into NVF3 series inverter which makes the operation and debugging more convenient;
- The built-in torque control function is suitable for wire drawing machine and other special equipment and can achieve constant tension control;
- The built-in intelligent PID control and sleep functions realize high-efficiency energy saving and unattended automatic control;
- Simple PLC control can realize the variable speed operation of the inverter in accordance with a certain law, which can not only define a circular multi-frequency in the function code, but also define the operation time, direction and number of cycles of multi-frequency in the function code;
- The built-in RS485 communication interface and built-in Modbus-RTU and Modbus-ASCII protocols in line with international standards can easily structure the system network, perfectly realizing the barrier-free communication with the industrial machine;
- Common DC busbar design: Multiple inverters can be parallelly connected by the common DC busbar, which can share the braking feedback energy, avoid over-voltage and stabilize the DC busbar voltage of a single inverter to ensure the continuous and stable operation of the equipment;
- With wobble control function, and suitable for textile and other industries.

2.5 Strong environmental adaptability

- The environmental adaptability is strong when the temperature of the operating environment is at $-10\text{ }^{\circ}\text{C} \sim +40\text{ }^{\circ}\text{C}$. When the temperature is over $40\text{ }^{\circ}\text{C}$, use in accordance with 1% decrease per increase of $1\text{ }^{\circ}\text{C}$;
- The wide input voltage range with the fluctuation range of $380\text{V} \pm 15\%$ can adapt to different civil and industrial power grids;
- Circuit boards use the conformal coating process, which can adapt to a variety of complex conditions.

3. Rich software features

DC braking when starting	<p>Stop and restart the free running motor</p> <p>When the motor turns at irregular directions during the free running, the motor is immediately started automatically after being stopped by DC braking.</p>	Speed tracking operation	Start with the speed of motor under coast stop. The motor under coast stop can be introduced to the set frequency automatically without the speed detector.
Automatic voltage regulation (AVR)	<p>Ensure the stability of output voltage during the operation of inverter</p> <p>When the grid voltage fluctuates, the output voltage of the inverter does not change with the fluctuation of the grid voltage.</p>	Frequency hopping control	<p>Skip the specific frequency to prevent the vibration of the mechanical system</p> <p>Run and automatically avoid the resonance point during the operation at the constant speed in order to prevent the vibration of the mechanical system.</p>
Automatic current limiting	When the load fluctuation exceeds the level of current limiting, it will be automatically adjusted to always keep the current within the allowable range.	Multi-speed operation	<p>Run the program at the set speeds</p> <p>According to the signal combination, run at the internally stored frequency. The multi-speed control can also be achieved through PLC and limit switches</p>
Torque limit	<p>Protect the machinery and ensure the reliable operation of machinery and equipment</p> <p>The torque generated by the motor can be controlled within the set value, which helps to protect the machinery.</p>	Energy saving operation	<p>Automatically operate at the maximum efficiency</p> <p>According to the load and rotational speed, detect the load current and always provide voltage with the maximum efficiency for the motor to achieve the most efficient energy-saving operation.</p>
Frequency detection	<p>Detect the frequency for the interlocking of brakes</p> <p>When the output frequency exceeds the set value, output the signal to control the interlocking of external equipment.</p>	Fault recording	<p>Automatically store the fault information</p> <p>When a fault alarm occurs, the current, voltage and fault type will be automatically recorded to provide a reference for the judgement of fault causes.</p>
Wobble frequency control	<p>Wobble up and down centering on the set frequency</p> <p>The wobble frequency function applies to the textile and chemical fiber industries and occasions needing traversing and winding.</p>	Pump sleep control	<p>Reduce mechanical wears</p> <p>When the water consumption at night is very small and the output frequency of the inverter is lower than the sleep frequency, the inverter will be on the sleep state.</p>
Fault reset	<p>Improve the reliability of continuous operation</p> <p>Even if a fault is detected in the inverter, it will automatically reset after self-diagnosis and will restart operation without stopping the motor. The times of automatic reset are 3 times.</p>	PID control	<p>Automatically control the process</p> <p>Conduct PID operation inside the inverter, and use the operation result as the frequency command for the quantitative control of pressure, flow rate and air volume.</p>
Simple PLC	<p>Define the basic logical sequence of the equipment to achieve the automatic control</p> <p>The operating mode, operating frequency, running direction and acceleration and deceleration times of the built-in PLC can be set in segmentation separately</p>	Overvoltage suppression	<p>Prevent overvoltage and fault trip</p> <p>It is effective to the operation of punch having the regeneration state due to the crank movement. Increase or decrease the operation frequency according to the regeneration state to suppress the overvoltage.</p>
Droop control	<p>Achieve the load sharing</p> <p>The droop control is also known as the load distribution. This function can achieve the load sharing when multiple motors drag the same load.</p>	Automatic torque increase	<p>Increase the low frequency output torque in V/F control mode</p> <p>The manual / automatic torque increase in V/F mode can effectively increase the low frequency torque of the inverter.</p>
High-speed pulse input	<p>Achieve the highly precise speed control</p> <p>Realize the external of the equipment controlling the operating frequency through the high-speed pulse signal or as the occasion at the PID feedback channel.</p>	Multi-stage closed-loop control	<p>Meet the requirements for different pressure settings at different time buckets</p> <p>The multi-stage closed-loop setting control can meet the requirements for different pressures at different time buckets in occasions such as water supply and gas supply so as to reduce waste and achieve energy efficiency.</p>
High-speed pulse output	<p>Real-time monitoring of parameters of the inverter to achieve the multi-machine linkage</p> <p>Realize the set frequency, operating frequency, output current, output voltage, motor speed and other physical output, and can also be applied to the linkage of multiple inverters.</p>	Complete V/F separation	<p>Fully realize the independent adjustment of the output voltage and output frequency</p> <p>Realize the complete separation of V and F, that is, users can set the voltage and frequency giving channels separately to combine into a real-time V/F curve for torque motor control.</p>

4. Main parameters and technical performance

4.1 Specifications parameters

Input voltage range	Three-phase	380V			
Inverter power (kW)	1.5/PS4,1.5/TS4	2.2/PS4,2.2/TS4	3.7/PS4,3.7/TS4	5.5/PS4,5.5/TS4	
Applicable motor power (kW)	1.5	2.2	3.7	5.5	
Rated output current (A)	3.8	5.1	9.0	13	

Input voltage range	Three-phase	380V			
Inverter power (kW)	7.5/PS4,7.5/TS4	11/PS4,11/TS4	15/PS4,15/TS4	18.5/PS4,18.5/TS4	22/PS4,22/TS4
Applicable motor power (kW)	7.5	11	15	18.5	22
Rated output current (A)	15	25	32	37	45

Input voltage range	Three-phase	380V			
Inverter power (kW)	30/PS4,30/TS4	37/PS4,37/TS4	45/PS4,45/TS4	55/PS4,55/TS4	75/PS4,75/TS4
Applicable motor power (kW)	30	37	45	55	75
Rated output current (A)	60	75	91	112	150

Input voltage range	Three-phase	380V			
Inverter power (kW)	90/PS4,90/TS4	110/PS4,110/TS4	132/PS4,132/TS4	160/PS4,160/TS4	185/PS4,185/TS4
Applicable motor power (kW)	90	110	132	160	185
Rated output current (A)	176	210	253	304	340

Input voltage range	Three-phase	380V			
Inverter power (kW)	200/PS4,200/TS4	220/PS4,220/TS4	250/PS4,250/TS4	280/PS4,280/TS4	315/PS4
Applicable motor power (kW)	200	220	250	280	315
Rated output current (A)	377	426	465	520	585

Input voltage range	Three-phase	380V	
Inverter power (kW)	315/TS4	355/TS4,355/PS4	400/TS4,400/PS4
Applicable motor power (kW)	315	355	400
Rated output current (A)	585	690	750

4.2 Standard technical parameters

Input and output character	Input voltage range: 380V (100% ± 15%)
	Input frequency range: (47 ~ 63) Hz
	Output voltage range: 0 ~ rated input voltage
	Output frequency range: typical type: (0 ~ 300) Hz; fan-pump type: (0 ~ 120) Hz

Peripheral interface	Programmable digital input: 7 channels (including 1 channel high-speed pulse input)
	Programmable analog input: AI1: (0 ~ 10) V or (0/4 ~ 20) mA input; AI2: (0 ~ 10) V or (0/4 ~ 20) mA input; AI3: (-10 ~ +10) V input; AI1 + AI2
	Open collector output: 2 channel outputs (including 1 channel high-speed pulse output)
	Relay output: 1 channel output; Analog output: 2 channel outputs, optional (0 ~ 10) V or (0/4 ~ 20) mA

Operating function character	Torque boost: automatic torque boost; manual torque increase by 0.1% ~ 30.0%
	Energy consumption braking: built-in or external braking unit, with external braking resistor
	DC braking: optional DC braking at start and stopping, operating frequency (0 ~ 60) Hz, braking current (0 ~ 100) % rated current, operating time (0.0 ~ 30.0) s
	Jog control: jog frequency range: (0 ~ 50) Hz, jog acceleration and deceleration time (0.1 ~ 6000.0) s
	Multi-speed operation: realizing the multi-speed operation through building in the simple PLC or controlling the multi-function terminal
	Automatic voltage regulation (AVR): automatically maintaining the constant output voltage when the grid voltage changes
	Automatic current limiting: automatically limiting the current during operation to prevent frequent over-current and fault trip
Technical characters	Built-in PID controller: easily constitute the closed-loop control system
	Custom MF function key: MF key can be set as jog operation, free stop and fast stop
	Protection function: providing more than 20 kinds of fault protection functions, such as over-current, overvoltage, undervoltage, overheating, phase failure, overload and PID disconnection protections

Technical characters	Control mode: without PG vector control, with PG vector control, without PG V/F control, with PG V/F control
	Overload capacity: typical type: 1min at 150% of rated current; fan-pump type: 1min at 120% of rated current
	Starting torque: without PG vector control: 0.5Hz/150% (rated torque); with PG vector control: 0.5Hz/180% (rated torque)
	Speed regulation ratio: without PG vector control: 1: 100; with PG vector control: 1: 1000
	Speed control accuracy: (without PG vector control): ± 0.2% maximum speed; (with PG vector control): ± 0.01% maximum speed
Carrier wave: (0.5 ~ 15) kHz	

Structure	Protection class: IP20
	Braking unit: the braking unit is the standard configuration to models below 22kW and is optional to models above 22kW.
	Cooling method: the full series of NVF3 inverter use the high-speed DC fan for cooling.

5. Basic operation wiring diagram

5.1 Standard wiring diagram

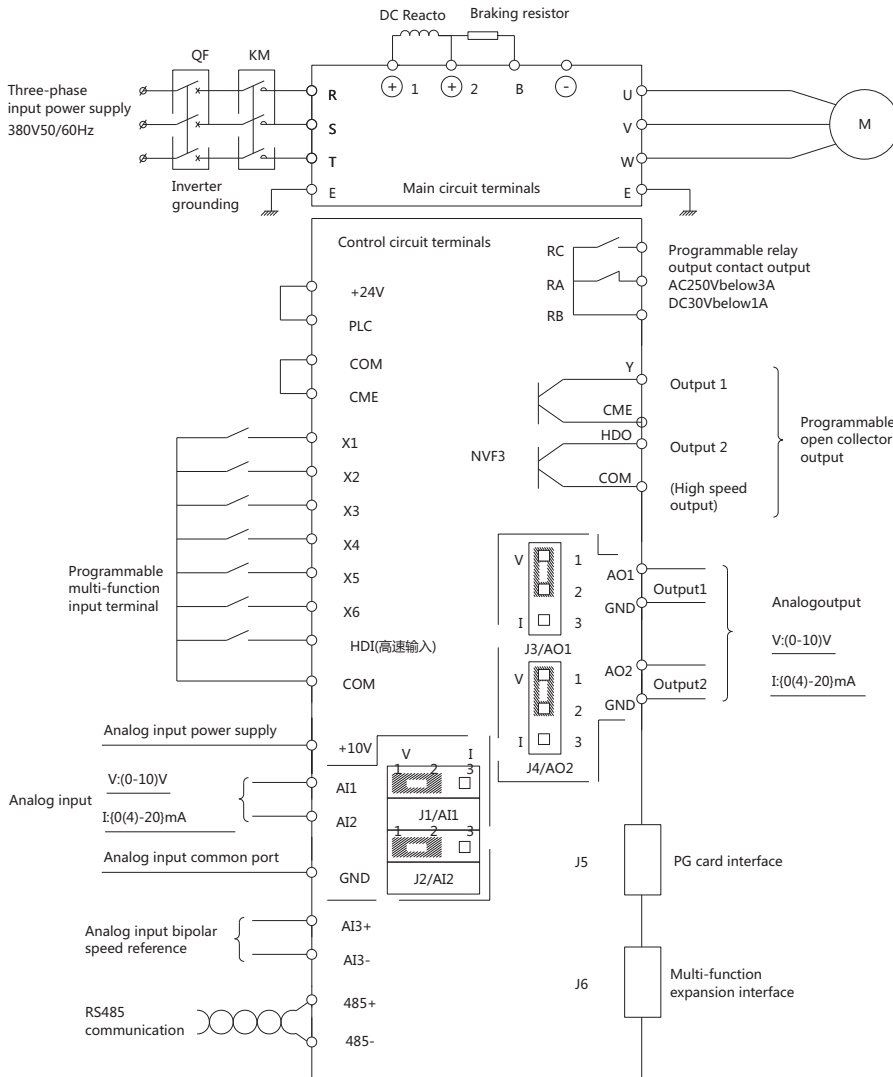

Standard wiring diagram for NVF3-1.5/TS4 ~ 315/PS4 models

J1, J2, J3 and J4 jumper selection:

J1, J2 positions (AI1, AI2 analog input interface):

When connect 1 to 2: 0V ~ 10V analog voltage input; When connect 2 to 3: 0/4mA ~ 20mA analog current input

J3, J4 positions (AO1, AO2 analog output interface):

When connect 1 to 2: 0V ~ 10V analog voltage output; When connect 2 to 3: 0/4mA ~ 20mA analog current output

5.2 Notes of main circuit terminals

Terminal mark	Terminal name and description
R, S, T	AC power input terminal, connecting power frequency three-phase power supply 380V
⊕、⊖	DC power input terminal, connecting the external braking unit
⊕、⊖	DC busbar positive pole, connecting DC reactor
⊕、B	Connecting the braking resistor terminal
U, V, W, ⊕、⊖、Ⓚ	AC output terminal, connecting the motor
⊕	Ground terminal, for inverter grounding

5.3 Descriptions of control circuit terminals

Type	Terminal screen printing	Name	Description of terminal function	Specifications
Power supply	+10V	+10V power supply	External + 10V reference power supply	Maximum allowable output current: 5mA
	GND	+10V GND	Reference grounds of analog signals and + 10V power supply	Internal isolation from COM and CME
Analog input	AI1	Analog single-ended input Ai1	Receive the analog voltage or current single-ended input, with voltage / current input being selected by jumper J1 / Ai1 of the control panel (reference ground: GND)	Input voltage range: -10V ~ 10V (input impedance: 45kΩ), resolution: 1/4000
	AI2	Analog single-ended input Ai2	Receive the analog voltage or current single-ended input, with voltage / current input being selected by jumper J2 / AI2 of the control panel (reference ground: GND)	Input current range: 0mA ~ 20 mA, resolution: 1/2000 (jumper required)
	AI3+	Analog voltage differential input AI3+ or analog voltage single-ended input	When receiving the analog voltage differential input, AI3+ is the non-inverting input terminal and AI3- is the inverting input terminal; when receiving the analog voltage single-ended input, AI3+ is the signal input terminal and AI3- should be connected to GND (reference ground: GND).	Input voltage range: -10V ~ 10V (input impedance: 15kΩ), resolution: 1/4000
	AI3-	Analog voltage differential input AI3- or analog voltage single-ended input		
Analog output	A01	Analog output 1	Provide analog voltage / current output with the output voltage / current being selected by jumper AO1 of the control panel: see function code F6.11 Description for the factory default output voltage (reference: GND)	Voltage output range: (0 ~10) V Current output range: (0/4 ~20) mA
	A02	Analog output 2	Provide analog voltage / current output with the output voltage / current being selected by jumper AO2 of the control panel: see function code F6.12 Description for the factory default output voltage (reference: GND)	Voltage output range: (0 ~10) V Current output range: (0/4 ~20) mA
Communication	458+	RS485 communication interface	Positive terminal of 485 differential signal	Standard RS485 communication interface Please use twisted pair or shielded wire
	485-		Negative terminal of 485 differential signal	
Multi-function input terminal	X1	Multi-function input terminal 1	Be programmable as the multi-function binary input terminals, the description of functions of F5.01 ~ F5.07 input terminals in binary input terminals (F5 group)	Optocoupler isolation, input impedance: R= 3.3kΩ, X1 ~ X6 Maximum input frequency: 200Hz, HDI maximum input frequency: 100kHz Input voltage range: (20 ~ 24) V
	X2	Multi-function input terminal 2		
	X3	Multi-function input terminal 3		
	X4	Multi-function input terminal 4		
	X5	Multi-function input terminal 5		
	X6	Multi-function input terminal 6		
Multi-function output terminal	Y	Bidirectional open collector output terminal 1	Be programmable as the multi-function binary output terminals, the description of functions of F6.01 output terminal in binary input terminals (F6 group) (common port: CME)	Optocoupler isolation output: maximum operational voltage: 30V Maximum output current: 50mA
	HDO	Open collector pulse output terminal	Be programmable as the multi-function binary output terminals, the description of functions of F6.02 output terminal in binary input terminals (F6 group) (common port: CME)	Output frequency range: determined by F6.18, 100kHz maximum
Power supply	+24V	+24V power supply	External +24 V power supply	Maximum output current: 100mA
	PLC	Multi-function input common port	Common port of multi-function input terminal (short circuit with 24V)	Common port of X1 ~ X6 and HDI, internal isolation of PLC and 24V Internal isolation of COM, CME and GND Internal short circuit of CME and COM
	COM	24V power supply common port	A total of 1 common terminal, used together with other terminals	
CME	Y output common port	Common port of multi-function output terminal Y1 (short circuit with COM)		
Relay output terminal 1	RA	Relay output	Be programmable as the multi-function relay output terminals, the description of functions of F6.03 output terminal in binary output terminals (F6 group)	RA-RB: NC, RB-RC: NO Contact capacity: NO/NC: 5A/3A 250V See the usage method in F6 instructions. The overvoltage level of the input voltage of the relay output terminal is class II.
	RB			
	RC			



6. Overall and mounting dimension

Outline Drawing of Display Panel

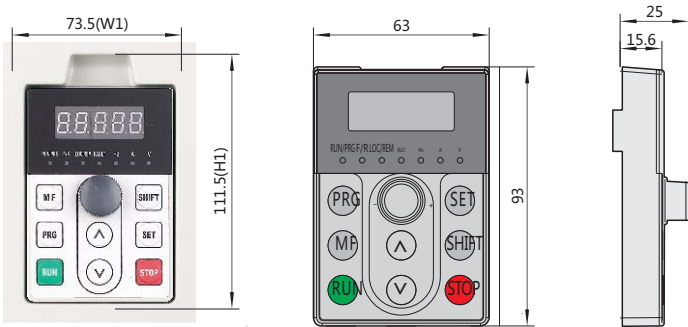

NVF3-1.5/TS4~11/PS4 Outline Drawings

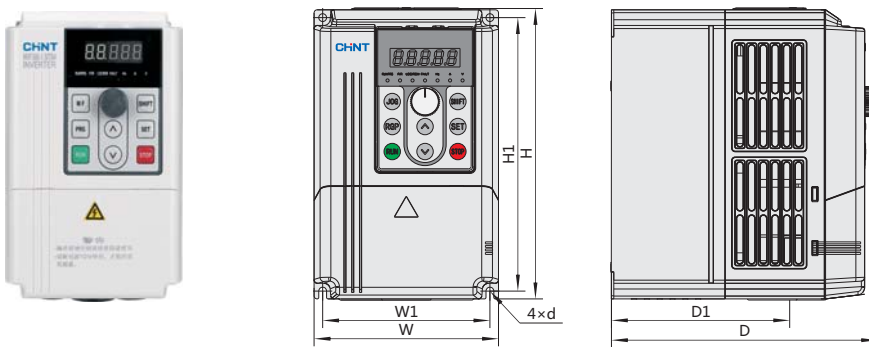

NVF3-11/TS4~NVF3-75/PS4 Outline Drawings

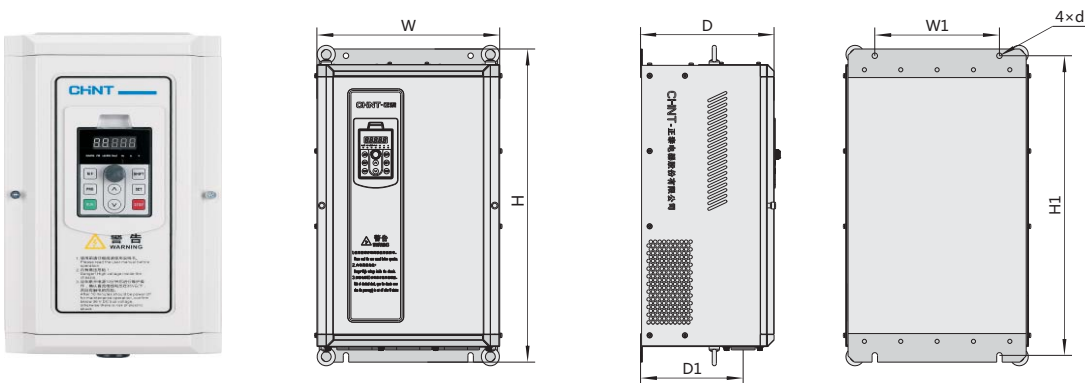

NVF3-75/TS4~NVF3-315/PS4 Outline Drawings

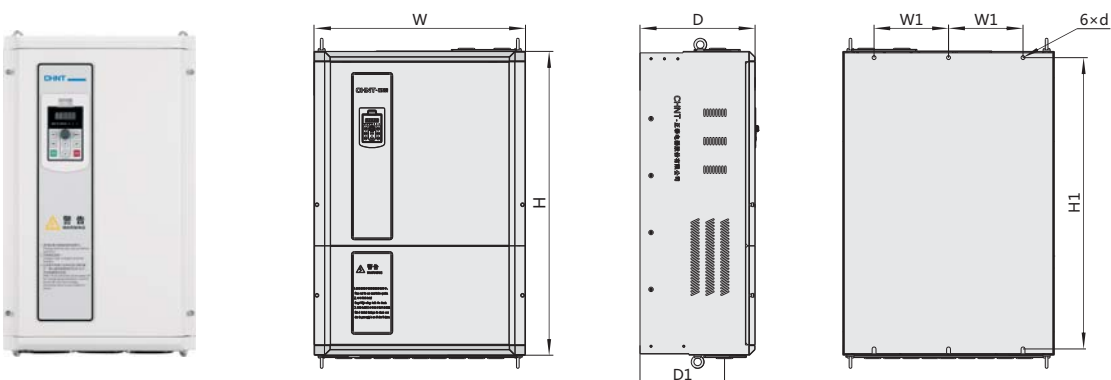

NVF3-315/TS4~NVF3-400/PS4 Outline Drawings

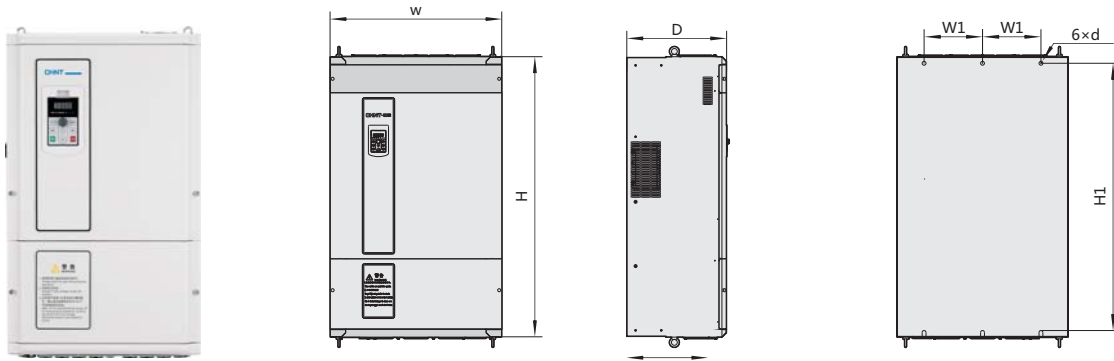



Model	Mounting Dimension							Weight kg
	W	H	D	W1	H1	D1	d	
Display panel				73.5	111.5	23.6		
NVF3-1.5/PS4 NVF3-1.5/TS4(2.2/PS4) NVF3-2.2/PS4	80	154	114	76	142	105	5	2.7
NVF3-2.2/TS4(3.7/PS4) NVF3-3.7/TS4(5.5/PS4)	118	187	173	107	175	110	5	3.1
NVF3-5.5/TS4(7.5/PS4) NVF3-7.5/TS4(11/PS4)	155	247	189	140	232	125	6	4.5
NVF3-11/TS4(15/PS4)	191	378	183	90	362	129	9	11
NVF3-15/TS4(18.5/PS4) NVF3-18.5/TS4(22/PS4)	215	426	213	120	407	164	10	15
NVF3-22/TS4(30/PS4) NVF3-30/TS4(37/PS4) NVF3-37/TS4(45/PS4)	300	527	230	166.6	506	179	10	25
NVF3-45/TS4(55/PS4) NVF3-55/TS4(75/PS4)	352	603	257	240	577	197.5	10	36
NVF3-75/TS4(90/PS4) NVF3-90/TS4(110/PS4)	406	631	272	126	600	224	10	65
NVF3-110/TS4(132/PS4) NVF3-132/TS4(160/PS4)	470	807	352	150	769	226.5	12	95
NVF3-160/TS4(185/PS4) NVF3-185/TS4(200/PS4) NVF3-200/TS4(220/PS4)	540	892	390	180	848	256	12	150
NVF3-220/TS4(250/PS4) NVF3-250/TS4(280/PS4) NVF3-280/TS4(315/PS4)	710	1020	386	250	978	284	13	165
NVF3-315/TS4(355/PS4) NVF3-355/TS4(400/PS4) NVF3-400/TS4(450/PS4)	734	1200	426	250	1152	298.5	16.5	280



7. Optional peripheral devices

Optional device name	Roles of optional device
Circuit breaker for wiring	Protect the power supply system when a short circuit occurs. Be sure to connect it between the AC main circuit power supply and AC reactor. If there is no reactor, connect it to the front of the inverter.
AC input reactor	Improve the input power factors, reduce the higher harmonics, and suppress surges on the power supply of inverter.
DC reactor	1.Improve or suppress the distortion rate of grid voltage and current waveform caused by the charging and discharging pulse currents of the filter capacitor; 2.Reduce the total harmonic distortion and improve the quality of grid power supply.
AC output reactor	1. Effectively inhibit the noise level vibration of motor; 2. Effectively suppress the differential mode noise within 100 KHz on the inverter output side; 3. Effectively absorb the surge voltage.
Braking unit	1. Control the pumping-up of busbar voltage, and have a certain protection to inverter; 2. Improve the braking capacity of inverter in the need of frequent braking.
Braking resistor	Consume the mechanical energy in the motor braking process in the form of thermal energy through the braking resistor, which can shorten the deceleration time of the inverter drive system.
Keyboard pallet	The keyboard pallet is needed when the inverter operation panel needs to be installed on the door of control cabinet, or when the remote cabinet control is required.
Display extension cable	It is used as an extension cable when using remote monitoring or pulling out the operation panel.

Accessory Selection Table

Inverter	Selection of braking accessories			AC input reactor			AC output reactor			DC reactor		
	Braking unit configuration (10% braking rate)	Braking resistor		Config uration	Rated current (A)	Induct ance (mH)	Config uration	Rated current (A)	Induct ance (mH)	Config uration	Rated current (A)	Induct ance (mH)
Resistance (Ω)		Power (W)										
NVF3-□/□□□												
1.5/PS4、1.5/TS4	Standard built-in accessories of the braking unit (including 22/PS4 models)	400	260	Optional external accessorie	3.7	2.239	Optional external accessorie	3	2.1	No need to select DC reactor	—	—
2.2/PS4、2.2/TS4		250	260		5.5	2.18		6.3	1.5		—	—
3.7/PS4、3.7/TS4		150	390		9	1.85		11	1.1		—	—
5.5/PS4、5.5/TS4		100	520		13	1.56		16	0.8		—	—
7.5/PS4、7.5/TS4		75	780		18	1		18	0.65		—	—
11/PS4、11/TS4		50	1040		24	0.52		28	0.33		—	—
15/PS4、15/TS4		40	1560		34	0.397		35	0.25		—	—
18.5/PS4、18.5/TS4		32	4800		38	0.352		40	0.2		—	—
22/PS4、22/TS4	Optional built-in accessories of the braking unit (including 110/PS4 models)	27.2	4800		50	0.26		50	0.18	Optional external accessories (including 110/PS4 models)	70	0.9
30/PS4、30/TS4		20	6000		60	0.24		63	0.09		80	0.86
37/PS4、37/TS4		16	7000		75	0.235		80	0.08		100	0.7
45/PS4、45/TS4		13.6	9600		91	0.17		100	0.06		120	0.58
55/PS4、55/TS4		10	12000		112	0.16		125	0.04		146	0.47
75/PS4、75/TS4		6.8	12000		150	0.12		160	0.035		160	0.36
90/PS4、90/TS4		6.8	12000		200	0.0705		200	0.023		180	0.33
110/PS4、110/TS4		6	20000		224	0.0692		224	0.016		250	0.24
132/PS4、132/TS4	Optional external accessories of the braking unit	6	25000	280	0.0503	280	0.016	280	0.24			
160/PS4、160/TS4		2.5	50000	315	0.0447	315	0.013	340	0.16			
185/PS4、185/TS4				400	0.0352	400	0.011	460	0.09			
200/PS4、200/TS4				400	0.0352	400	0.011	460	0.09			
220/PS4、220/TS4				450	0.0313	560	0.009	500	0.82			
250/PS4、250/TS4				560	0.0251	600	0.008	600	0.072			
280/PS4、280/TS4				560	0.0251	600	0.008	600	0.072			
315/PS4				640	0.0224	690	0.006	700	0.068			
Picture of display extension cable and display panel pallet	Display extension cable						Display panel pallet					
Note: If the inverter panel needs to be pulled out for operation, it should be specified when ordering and indicate the length of the display extension line.												

8. Ordering instructions

Please select the required model and specifications according to the instructions of the model and meaning:

For example: Three-phase 380V typical type: NVF3-75/TS4

Three-phase 380V fan-pump type: NVF3-75/PS4

8.1 Model selection guide

8.1.1 In order to ensure the reliable operation of inverter, the power of inverter must be greater than or equal to the power of motor.

8.1.2 The typical type inverter is mainly used for loads other than fan and pump, such as crane, rolling mill, mixer, ball mill, centrifuge and other heavy loads.

8.1.3 The fan-pump type inverter is mainly used for light loads such as fan and pump. If the load running current is greater than 0.9 times the rated current, it is recommended to select the fan-pump type inverter with a larger gear or the typical type inverter with the same power.

9. Custom frequency conversion control cabinet

Various frequency conversion control cabinets can be customized according to requirements of the production process.

